

GATE VALVE RISING STEM OS&Y

Valves are manufactured and tested in accordance with BS 5150 PN 10 / 16 / 25, TIS 432 PN 6 / 10 / 16 and also meet the requirements of MSS-SP-70 class 125 / 250, Suitable for all types of water, air and steam.

SIZE : 50 mm. - 1500 mm.



Fig.110



Fig.112

FEATURES

- IBBM (iron body and bronze mounted) , stainless steel trim , and all iron trim is also available.
- Valve ends can be flanged or screwed.
- Flanged drilling to suit ANSI B16.1 , BS4504 , BS10 , BS 4772 , ISO , AS2129 , DIN , JIS and etc.
- Various types of operators such as handwheel , chainwheel , spur gear , bevel gear, pneumatic , hydraulic and electric actuator can be provided upon requested.
- Special accessories like by-pass unit , valve locking device , tapped bosses , drain plug , pipe cover , indicator and limit switches are also available.

VALVE FIGURES NO.

Fig .100 With Handwheel or Chainwheel or Cap or Operating Nut or Actuator.

Fig .102 With Indicator , Handwheel or Chainwheel or Cap or Operating Nut or Actuator.

Fig .152 With Gear , Handwheel or Chainwheel or Cap or Operating Nut or Actuator.

Fig .110 Without Gear , By Pass Valve, Handwheel or Chainwheel or Cap or Operating Nut or Actuator.

DESIGN SPECIFICATIONS

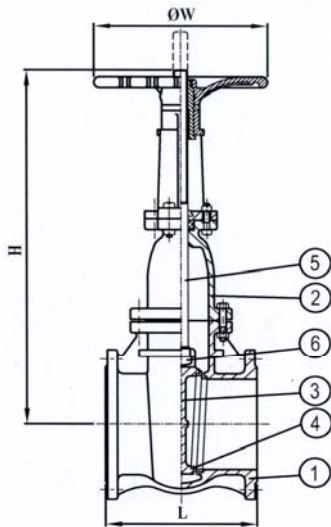

Fig.110

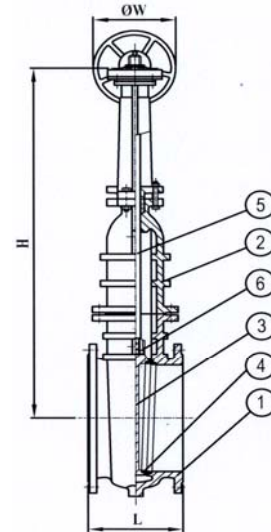

Fig.112

SIZE DN	L (mm.)		H (mm.)	ØW (mm.)	APPROX. WEIGHT(kg.)			No OF TURN
	PN 10/16	PN25			PN10	PN16	PN25	
50	178	216	293	160	13	13	14	13
65	190	241	318	180	17	17	19	16.5
80	203	283	368	198	24	24	27	20
100	229	305	450	250	39	39	44	25
125	254	381	511	280	51.5	51.5	61	26
150	267	403	614	300	68	68	84	31
200	292	419	764	355	113	127	136	41
250	330	457	919	395	170	174	203	51
300	356	502	1061	450	238	242	293	49
350	381	572	1278	450	375	391	470	57
400	406	610	1513	700	603	622	716	65
450	432	660	1643	700	690	722	833	73
500	457	711	1800	700	917	968	1103	81
600	508	787	2115	700	1378	1470	1636	97.5

SIZE DN	L (mm.)		H (mm.)	ØW (mm.)	APPROX. WEIGHT(kg.)			No OF TURN
	PN 10/16	PN25			PN10	PN16	PN25	
350	381	572	1325	280	435	451	530	143
400	406	610	1560	450	698	717	811	196
450	432	660	1675	450	784	816	927	220
500	457	711	1855	450	1012	1063	1198	244
600	508	787	2245	500	1900	1992	2158	390
700	610	—	2448	500	2314	2383	—	341
750	610	—	2563	500	2540	2609	—	365
800	660	—	2718	500	3560	3640	—	486
900	711	—	2985	500	4114	4214	—	546
1000	811	—	3375	623	4670	4818	—	810
1050	811	—	3760	623	5230	5388	—	820
1200	838	—	4140	623	5780	5968	—	970
1400	860	—	4530	623	6330	6482	—	1700
1500	900	—	4920	623	6890	7131	—	1819

NO.	PARTS NAME	MATERIAL	ASTM.DESIGNTION	BS.STANDARD
1	Body	Cast Iron	A 126 Class B	1452 Grade 220,250,300
2	Bonnet		A 536 Grade 65-45-12	420/12
3	Disc	Ductile Iron	A 536 Grade 80-55-6 A 395	2789 Grade 500/7 600/3
4	Seat	Bronze	B 62	1400 LG.2
		Stainless Steel	A276 Type 304,316,431	970 Grade 304, 316, 431
		Aluminium Bronze	B 148 C95200	1400 AB.1
5	Stem	High Tensile Bronze	B16 B21	2872 CZ 114
		Stainless Steel	A276 Type 304,316,431	970 Grade 304, 316, 431
		Aluminium Bronze	B 124 B 132 B 150	2872 CA 104
6	Stem Nut	Aluminium Bronze	B148 C95200	1400 AB.1
		Bronze	B62	1400 LG.2
		Stainless Steel	A276 Type 304,316,431	970 Grade 304, 316, 431



Siam Cast Iron Works Co.,Ltd.

Factory: 1/12 Moo 2, Samutsakorn Industrial Estate, Soi 7,
Rama II Road, Muang, Samutsakorn 74000, Thailand

Tel: (6634)829-200 Fax: (6634)829-222 E-mail: sci@scivalve.com



ISO 9001
File No. A4645