

GATE VALVE NON RISING STEM

Valves are manufactured and tested in accordance with BS 5150 PN10/16/25, TIS 432 PN 6 / 10 / 16 and also meet the requirements of MSS-SP-70 class 125 / 250, Suitable for all types of water, air and steam.

SIZE : 50 mm. - 1500 mm.



FEATURES

- IBBM (iron body and bronze mounted) , stainless steel trim , and all iron trim is also available.
- Valve ends can be flanged , screwed and spigot.
- Flanged drilling to suit ANSI B16.1 , BS4504 , BS10 , BS 4772 , ISO 2531, AS2129 , DIN , JIS and etc.
- Various types of operators such as handwheel , operating nut or cap , chainwheel , spur gear , bevel gear, pneumatic , hydraulic and electric actuator can be provided upon requested.
- Special accessories like by-pass unit , valve locking device , tapped bosses , indicator and limit switches are also available.

VALVE FIGURES NO.

Fig .100 With Handwheel or Chainwheel or Cap or Operating Nut or Actuator.

Fig .102 With Indicator , Handwheel or Chainwheel or Cap or Operating Nut or Actuator.

Fig .152 With Gear , Handwheel or Chainwheel or Cap or Operating Nut or Actuator.

Fig .110 Without Gear , By Pass Valve, Handwheel or Chainwheel or Cap or Operating Nut or Actuator.

DESIGN SPECIFICATIONS

WITHOUT GEAR

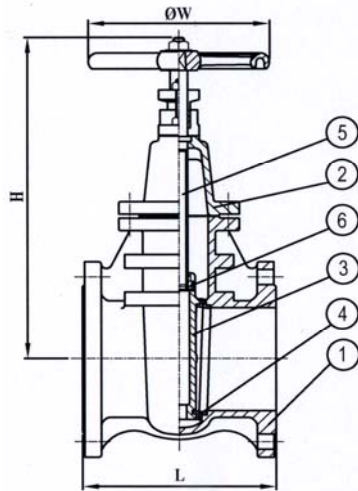

Fig.100

SIZE 50-600mm

SIZE DN	L (mm.)		H (mm.)	ØW (mm.)	APPROX. WEIGHT(kg.)			No OF TURN
	PN 10/16	PN25			PN10	PN16	PN25	
50	178	216	257	180	11	11	13	17.5
65	190	241	292	180	15	15	17	22
80	203	283	315	200	20	20	22	20
100	226	305	367	224	33	33	38	25
125	254	381	425	250	44	44	50	26
150	267	406	474	250	60	60	70	31
200	292	419	577	280	96	98	110	41
250	330	457	673	315	140	143	167	41
300	356	502	772	355	201	211	247	49
350	381	572	945	400	323	328	413	43
400	406	610	1075	450	460	490	571	49
450	432	660	1160	500	590	621	740	55
500	457	711	1275	623	831	869	1047	61
600	508	787	1490	623	1225	1275	1529	73

WITH GEAR

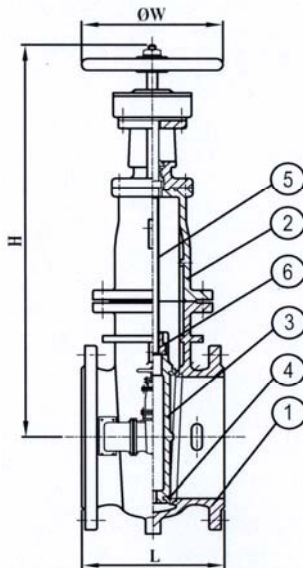

Fig.154

SIZE 350-1500mm

350	381	572	1205	280	342	355	432	108
400	406	610	1356	450	548	575	659	123
450	432	660	1440	450	673	708	823	165
500	457	711	1543	450	897	935	1113	183
600	508	787	1857	500	1469	1556	1773	292
700	610	-	2024	500	2058	2125	-	340
750	610	-	2100	500	2440	2529	-	364
800	660	-	2190	623	2758	2844	-	585
900	711	-	2376	623	3850	3945	-	456
1000	811	-	2730	623	5236	5375	-	810
1050	811	-	2920	623	5921	6071	-	850
1200	838	-	3110	623	7730	7909	-	970
1400	860	-	3412	623	10224	10369	-	1700
1500	900	-	3686	623	11471	11700	-	2183

NO.	PARTS NAME	MATERIAL	ASTM.DESIGNTION	BS.STANDARD
1	Body	Cast Iron	A 126 Class B	1452 Grade 220,250,300
2	Bonnet		A 536 Grade 65-45-12	420/12
3	Disc	Ductile Iron	A 536 Grade 80-55-6 A 395	2789 Grade 500/7 600/3
4	Seat	Bronze	B 62	1400 LG.2
		Stainless Steel	A276 Type 304,431	970 Grade 304, 316, 431
		Aluminium Bronze	B 148 C95200	1400 AB.1
5	Stem	High Tensile Bronze	B16 B21	2872 CZ 114
		Stainless Steel	A276 Type 304,316,431	970 Grade 304, 316, 431
		Aluminium Bronze	B 124 B 132 B 150	2872 CA 104
6	Stem Nut	Bronze	B 62	1400 LG.2
		Aluminium Bronze	B148 C95200	1400 AB.1
		Stainless Steel	A276 Type 304,316,431	970 Grade 304, 316, 431



Siam Cast Iron Works Co.,Ltd.

Factory: 1/12 Moo 2, Samutsakorn Industrial Estate, Soi 7,

Rama II Road, Muang, Samutsakorn 74000, Thailand

Tel: (6634)829-200 Fax. (6634)829-222 E-mail: sci@scivalve.com



ISO 9001
File No. A4645