

RUBBER FLAPPER CHECK VALVE



SIMPLICITY IN DESIGN NO MAINTENANCE REQUIRED NON-SLAM PERFORMANCE

DESCRIPTIONS

Valves are manufactured and tested in accordance with MSS-SP-71 class 250 and EN 12334 PN 16. The unique design of rubber flapper disc with the hi-strength fabric reinforced which creates an elastic spring effort to close-against the flow, combined with the tilted body seat (closing angle 35°) act to reduce the closing time, minimize the water hammer and flow reversal. The simplicity in design, three components (Body, Disc & Cover) in one valve, and disc, hinge & pin are integral in one piece with fully special rubber encapsulated offer for maintenance free, 1,000,00 continuous cycles tested with no sign of wear or distortion to the valve disc and seat, Body and Cover are Ductile iron. This valve will operate trouble free for a longer period compared to conventional check valves.

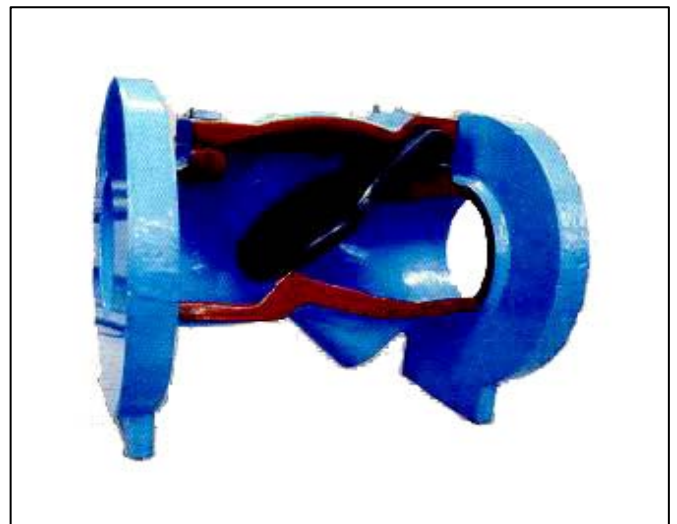

FEATURES

- Sizes are available from DN 50 mm. - DN 600 mm.(2"-24")
- Flange drilling to suit ANSI B16.1, EN 1092, BS 10, ANSI B16.5, AS 2129 and JIS.
- Optional accessories : Proximity switch, Backflow actuator, Oil dash-pot, Air release plug on the cover.

APPLICATIONS

Suitable for all type of water, air and steam 100°C. (For higher temperature, consult factory).

DESIGN SPECIFICATIONS

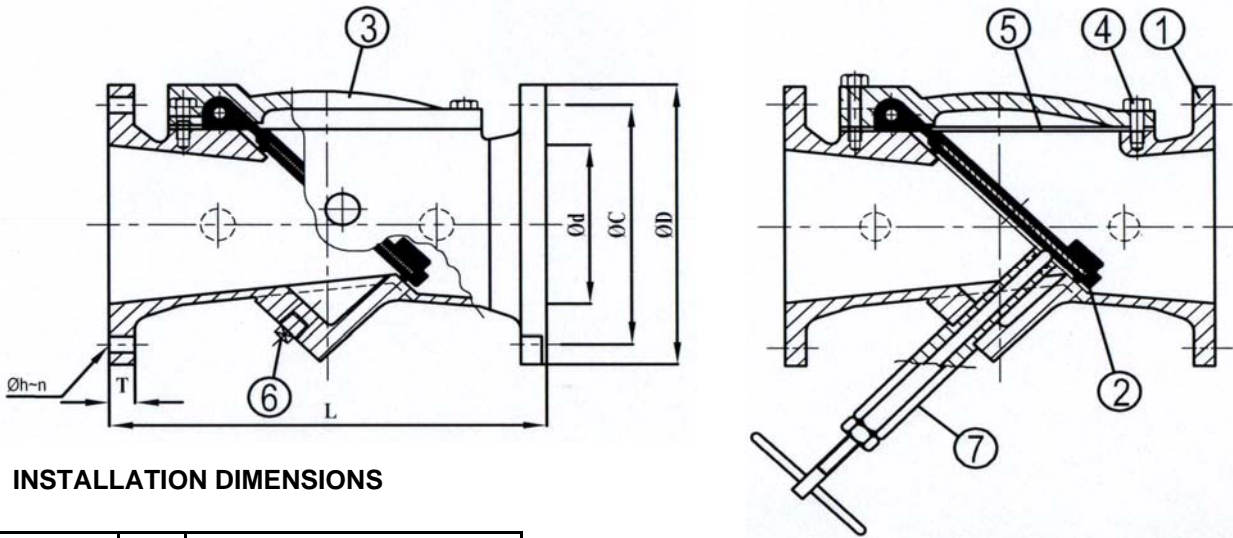

INSTALLATION DIMENSIONS

SIZE		L	ANSI B16.1 CL 125				
Ød in	mm		ØD	ØC	Øh	n	T
2	(50)	8	6	4 3/4	3/4	4	5/8
3	(80)	9 1/2	7 1/2	6	3/4	4	3/4
4	(100)	11 1/2	9	7 1/2	3/4	8	15/16
6	(150)	15	11	9 1/2	7/8	8	1
8	(200)	19 1/2	13 1/2	11 3/4	7/8	8	1 1/8
10	(250)	24 1/2	16	14 1/4	1	12	1 3/16
12	(300)	27 1/2	19	17	1	12	1 1/4
14	(350)	31	21	18 3/4	1 1/8	12	1 3/8
16	(400)	32	23 1/2	21 1/4	1 1/8	16	1 7/16
18	(450)	38	25	22 3/4	1 1/4	16	1 9/16
20	(500)	42	27 1/2	25	1 1/4	20	1 11/16
24	(600)	48	32	29 1/2	1 3/8	20	1 7/8

MATERIALS OF CONSTRUCTION

NO.	PARTS	MATERIAL	ASTM DESIGNATION	BS SPEC
1	Body	Ductile Iron	A536 Grade 65-45-12	EN1563-EN-GJS-500-7
2	Disc	Steel&Rubber(Buna N)	A36& D2000 AA7008	1506&2494
3	Cover	Ductile Iron	A536 Grade 65-45-12	EN1563-EN-GJS-500-7
4	Cover Bolt	Zinc Coated Steel	A 307 Grade B	4882
5	Cover Gasket	Rubber EPDM/NBR	D 2000 AA7008	2494
6	Plug	Malleable Iron	A 47	-
7	Backflow Actuator	-	-	-

HEAD LOSS CHART

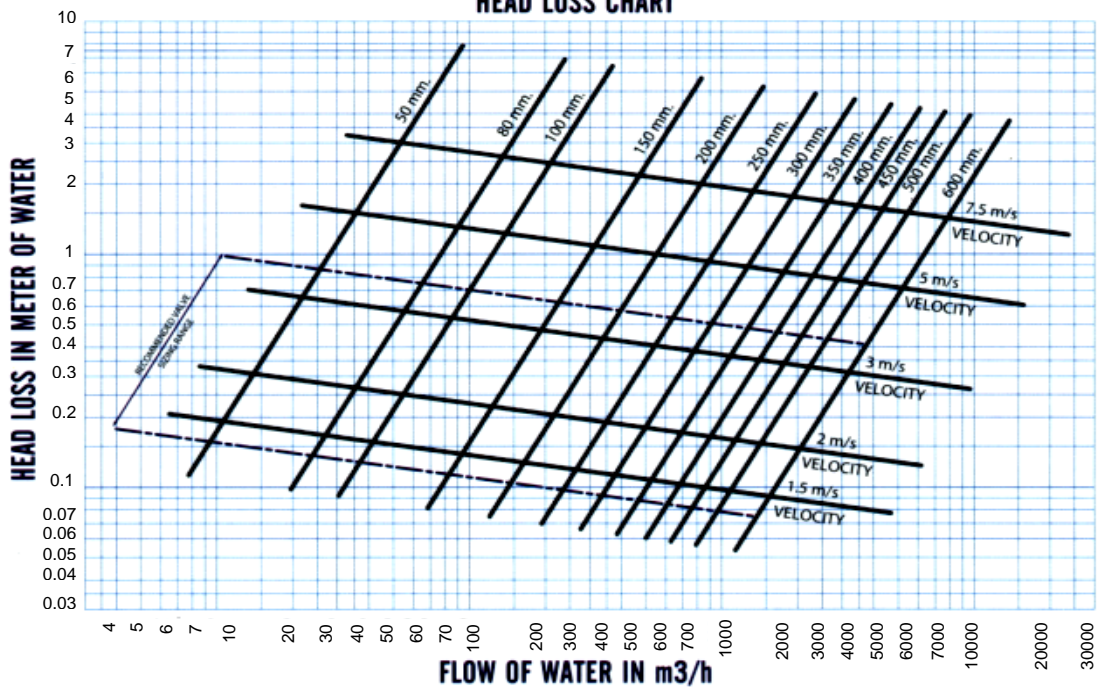

Siam Cast Iron Works Co., Ltd.

Factory: 1/12 Moo 2, Samutsakorn Industrial Estate, Soi 7,
Rama II Road, Muang, Samutsakorn 74000, Thailand
Tel: (6634)829-200 Fax: (6634)829-222 E-mail: sci@scivalve.com



ISO 9001
File No. A4645